

G9000 Uninterruptible Power Supply
Multi-level PWM IGBT Technology
White Paper

TOSHIBA

Leading Innovation >>>

TOSHIBA G9000 UPS

White Paper

Green UPS Solutions in Mission-Critical Facilities through Industry-Leading High-Efficiency Power Electronics

With the rising cost of energy and growing environmental concerns, building design and management of mission-critical applications have become even more challenging. To meet current and future demands in terms of efficiency, greenhouse emissions, reliability, layout reconfiguration and power availability, adoption of state-of-the-art UPS (Uninterruptible Power Supply) power electronics technology is a good practice to avoid obsolescence, reduce waste and enhance flexibility. This white paper examines the recent technological advances in power availability solutions and points out the many benefits end-users can achieve by using cutting edge industrial electronics.

Green Solutions in Mission-Critical Facilities through Industry-Leading High-Efficiency Power Electronics

Demands for mission-critical facilities have dramatically increased in recent years in particular to support the expansion of information-related businesses¹. A critical facility such as a data center requires an environmental controlled room and space to accommodate various electronics equipments as well as a high-availability power supply and protection system. It is well-known that building and running an environmentally controlled facility is costly. With the rising cost of energy and growing environmental concerns, building design and management of mission-critical applications have become even more challenging.

High level performance site infrastructure features redundant power capacity, fault tolerance, constant cooling and enough space for maintenance and future reconfiguration². Therefore, high efficiency and size effective uninterruptible power supplies play a key role in powering these critical applications at a low cost of ownership. Recent advances in power electronics have led to a new generation of higher efficiency UPS systems with compactness and higher efficiency to meet current and future demands in terms of efficiency, greenhouse emissions, reliability, layout reconfiguration and power availability.

This white paper examines the recent technological advances in power availability solutions and points out the many benefits end-users can achieve by using cutting edge industrial electronics.

¹ US Environmental Protection Agency Report to Congress on Server and Data Center Energy Efficiency (2007).

² The Uptime Institute.

Multilevel Power Converters for Higher Efficiency and Size Effective UPS Systems

A double conversion UPS typically has three power conversion stages (converter, inverter and chopper) as shown in Figure 1. Each power converter is basically an array of semiconductors (switches). These switches are arranged in such way that their commutation enables the synthesis of the required output voltage waveform.

FIGURE 1
Single line diagram of a double conversion UPS

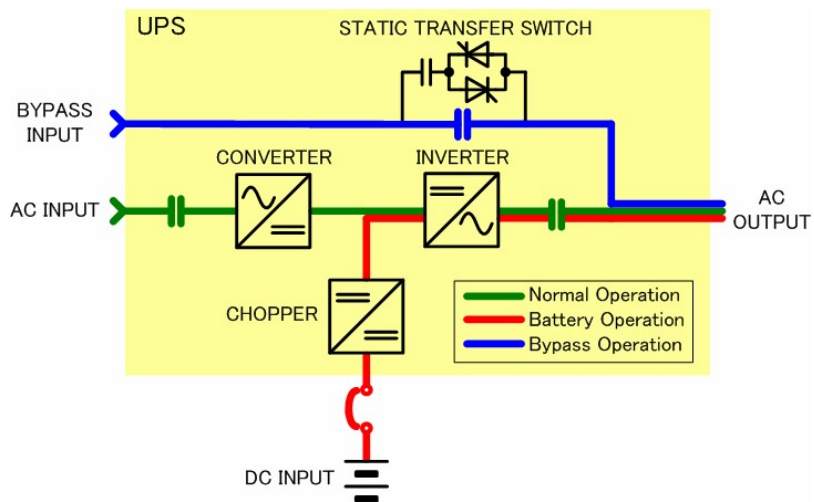

Conventional inverters have a configuration as shown in Figure 2. In this configuration, note that,

- n the voltage stress on each power switch can be as high as the DC link voltage E .
- n the output voltage at each terminal varies between two levels: $+E/2$ Volts and $-E/2$ Volts. Thus, the voltage variation (dv/dt) at the terminal is equal to E Volts.

FIGURE 2
A conventional 2-level 3-phase inverter circuit

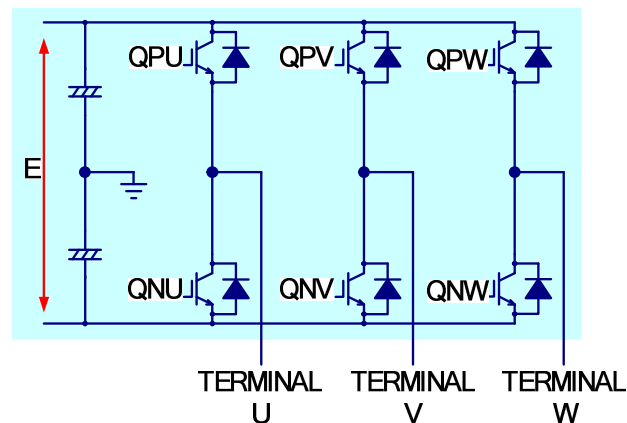

To illustrate the waveform synthesis using the conventional concept, consider its schematic diagram as shown in Figure 3. The line-to-line voltage (for example, terminals U and V) has three voltage levels (+E, 0, -E Volts) as a result of four possible combinations (Table 1). Figure 4 shows a train of variable-width pulses (line-to-line voltage) using a conventional inverter. To obtain a sinusoidal signal, filtering using bulky reactors is required to suppress high frequency components.

FIGURE 3
Equivalent circuit
of a conventional
2-level 3-phase
inverter

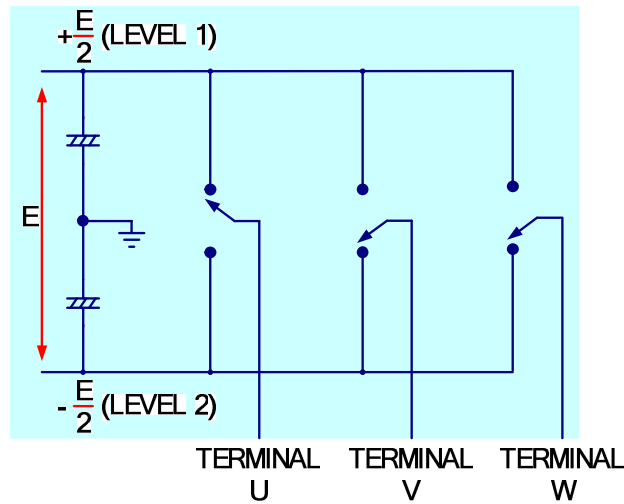
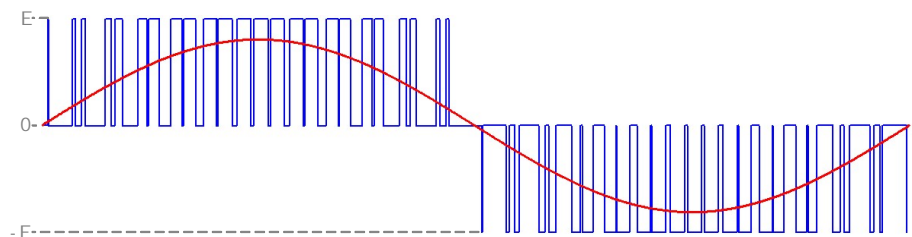

TABLE 1
Pattern of the
line-to-line output
voltage for a 2-level
inverter

Terminal U	Terminal V	Line-to-Line Voltage (U - V)
$+\frac{E}{2}$	$+\frac{E}{2}$	0
$+\frac{E}{2}$	$-\frac{E}{2}$	+ E
$-\frac{E}{2}$	$+\frac{E}{2}$	- E
$-\frac{E}{2}$	$-\frac{E}{2}$	0

FIGURE 4
Line-to-line voltage
in a conventional
2-level inverter



An alternative power conversion circuit arrangement called multilevel³ features several advantages over the conventional two-level converter including:

- n lower voltage stresses on power semiconductor devices;
- n considerable reduction of acoustic noise and electromagnetic interference;
- n higher efficiency (lower losses);
- n higher reliability;
- n compactness.

The most common multilevel structure is shown in Figure 5. In this sophisticated arrangement note that:

- n the voltage stress on each power switch is equal to $E/2$ Volts.
- n the output voltage at each terminal assumes one out of three levels: $+E/2$, 0 and $-E/2$ Volts.

This observation shows that:

- n voltage stresses on power switches are half of those in the conventional circuit;
- n the voltage variation (dv/dt) at each terminal is equal to $E/2$ Volts.

These findings imply that

- n voltage ratings of power semiconductors can be half of those in the conventional circuit widening design options.
- n significant noise reduction (acoustic noise and electromagnetic interference) is associated with the lower dv/dt .

FIGURE 5
A multilevel (3-level)
3-phase inverter
circuit

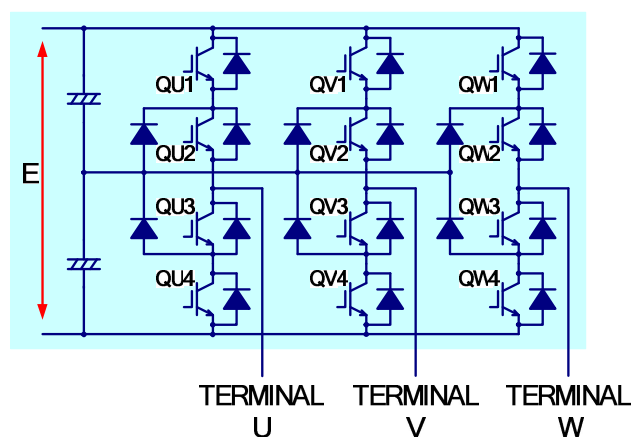

Due to this additional voltage level, the number of combinations to

³ The term multilevel was firstly coined in the paper: A. Nabae, I. Takahashi, and H. Akagi, "A new neutral-point-clamped PWM inverter", *IEEE Trans. Ind. Applicat.* Vol. IA-17, No. 5 (1981).

synthesize the line-to-line output voltage increases as well. Consider the circuit shown in Figure 6. Pattern of the line-to-line voltage (Table 2) shows nine possible combinations and five resulting voltage levels (+E, +E/2, 0, -E/2 and -E Volts). A train of variable-width pulses for a 3-level power processor is shown in Figure 7. The resulting output waveform tracks the sinusoidal much better than in the case of the conventional inverter.

FIGURE 6
Equivalent circuit of
a multilevel (3-level)
3-phase inverter
circuit

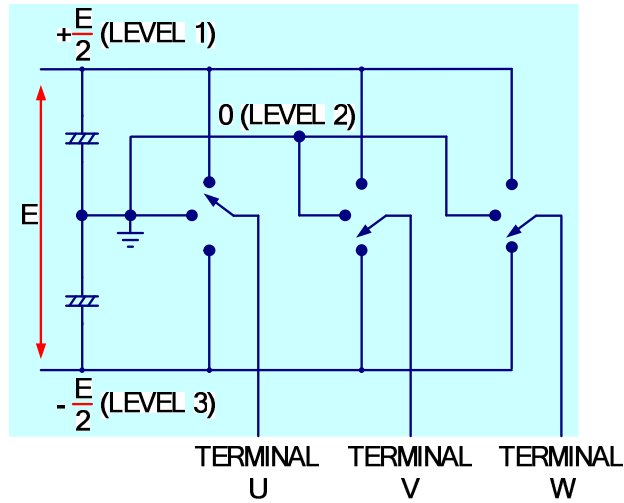
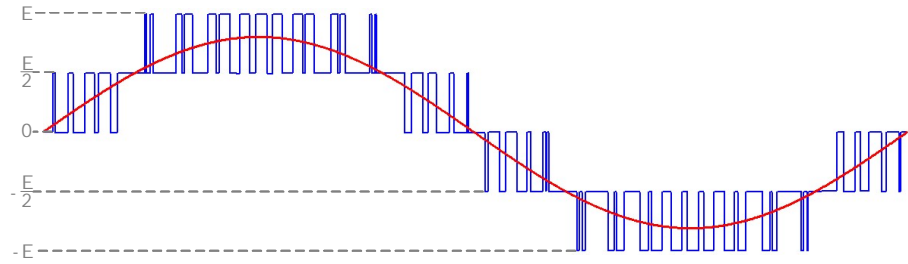

TABLE 2
Pattern of the
line-to-line output
voltage for a 3-level
inverter

Terminal U	Terminal V	Line-to-Line Voltage (U - V)
$+\frac{E}{2}$	$+\frac{E}{2}$	0
$+\frac{E}{2}$	0	$+\frac{E}{2}$
$+\frac{E}{2}$	$-\frac{E}{2}$	E
0	$+\frac{E}{2}$	$-\frac{E}{2}$
0	0	0
0	$-\frac{E}{2}$	$+\frac{E}{2}$
$-\frac{E}{2}$	$+\frac{E}{2}$	-E
$-\frac{E}{2}$	0	$-\frac{E}{2}$
$-\frac{E}{2}$	$-\frac{E}{2}$	0

FIGURE 7

Line-to-line voltage
in a 3-level inverter



Compactness is an inherent feature of multilevel converters.

This improvement in waveform synthesis results in considerable size/weight reduction and, consequently, space savings since a multilevel topology requires a smaller filter to obtain a clean sinusoidal waveform. Some simulation results demonstrate the difference between the conventional and the multilevel converter in terms of attenuation of high-frequency components. Figure 8 shows the inverter current and its harmonic spectrum (f_s : switching frequency) for, respectively (from top to bottom):

- n a conventional inverter with a 0.05 p.u. filter reactor;
- n a multilevel inverter with a 0.05 p.u. filter reactor;
- n a conventional inverter with a 0.10 p.u. filter reactor.

Note that, to match the current ripple and harmonic spectrum performance seen in a three-level converter, a two-level topology requires a larger reactor. Therefore, three-level based structures have a competitive advantage in terms of size/weight reduction.

FIGURE 8

Inverter current and its harmonic spectrum for various circuit configurations:
2-level with a 5% reactor (blue),
3-level with a 5% reactor (green) and
2-level with a 10% reactor (red).

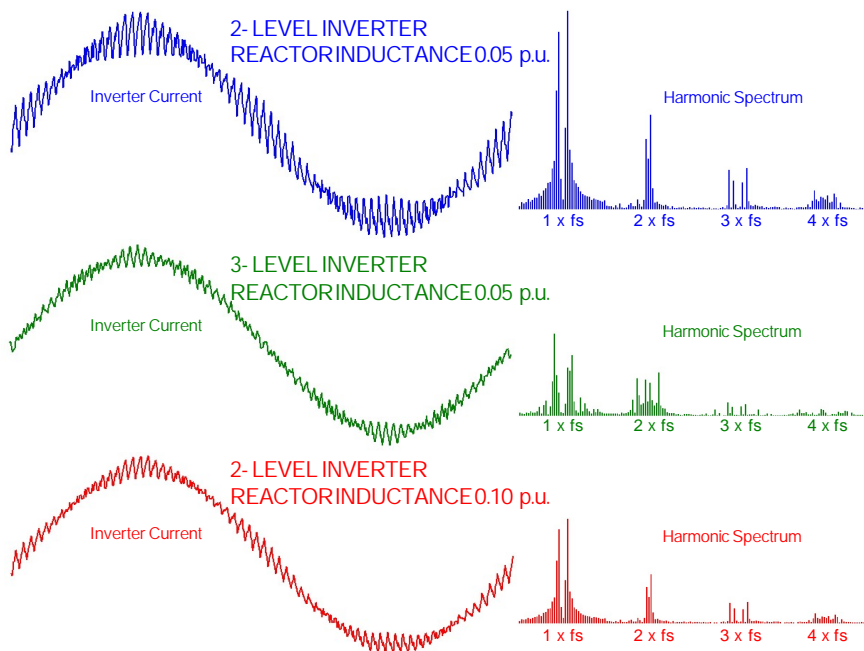

Another benefit of the multilevel concept is the improvement of power conversion efficiency. Due to the fact that three-level converters promote lower voltage stress on power semiconductors, voltage ratings of transistors and diodes can be lowered without compromise performance and reliability.

For example, a 3-phase 480V power converter using a two-level circuit requires a 1200V class IGBT, while a three-level circuit can be structured using an IGBT voltage class of 600V. This flexibility in design allows the selection of power semiconductors with better conduction and switching characteristics.

As an example, refer to the Figure 9 that shows the switching losses and saturation voltage for a typical 1200V- and a 600V-class IGBT of same generation from the same manufacturer. Although the saturation voltage is almost the same, a 600V class IGBT exhibits better switching characteristics.

FIGURE 9
Switching and saturation characteristics for a 1200V- and a 600V-class IGBT

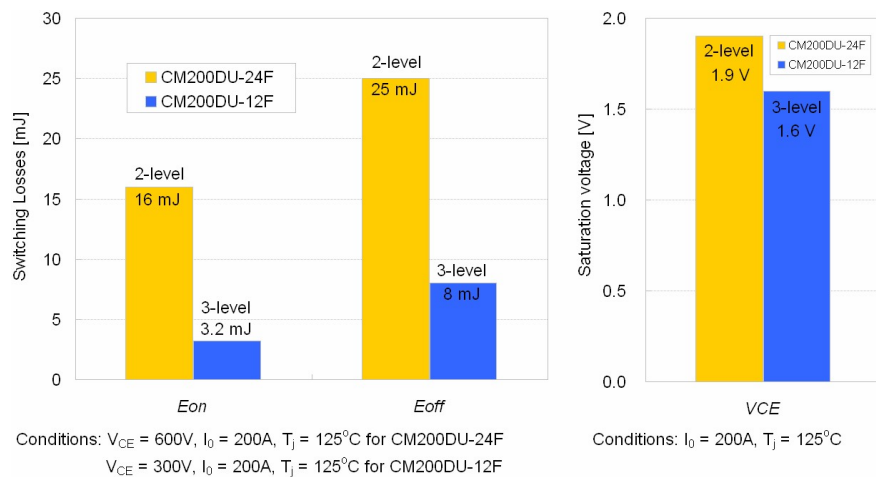

Conduction losses are a function of the current in the semiconductor and its saturation voltage. Thus, for a certain current level, from the point-of-view of conduction losses, since the number of transistors in a three-level power converter is the double as in a two-level circuit, this loss component constitutes a disadvantage for a three-level circuit.

However, in terms of switching losses, the three-level topology shows off

Due to the dramatic reduction of switching losses, a three-level UPS exhibits over 15% of reduction in power semiconductor losses.

an interesting improvement toward high efficiency. Basically, switching losses are a function of the voltage across the semiconductor, switching frequency, switch current, and the junction temperature. For a given switching frequency, current level and temperature, three-level converters show a dramatic reduction of switching losses due to the reduced voltage stress on each power switch and better characteristics of using an IGBT with lower voltage ratings.

Considering both types of losses in an UPS, the three-level concept realizes an overall improvement of power conversion efficiency. Figure 10 shows a typical scenario of power loss distribution in an UPS system for both circuit topologies. Despite of the fact that conduction losses almost doubles, switching losses are dramatically reduced in a three-level double-conversion topology. This loss reduction is translated into a higher efficiency UPS with lower thermal stresses on power semiconductors.

FIGURE 10
 Typical semiconductor losses distribution in an UPS system. Numbers for 3-level are referred to 2-level topology.

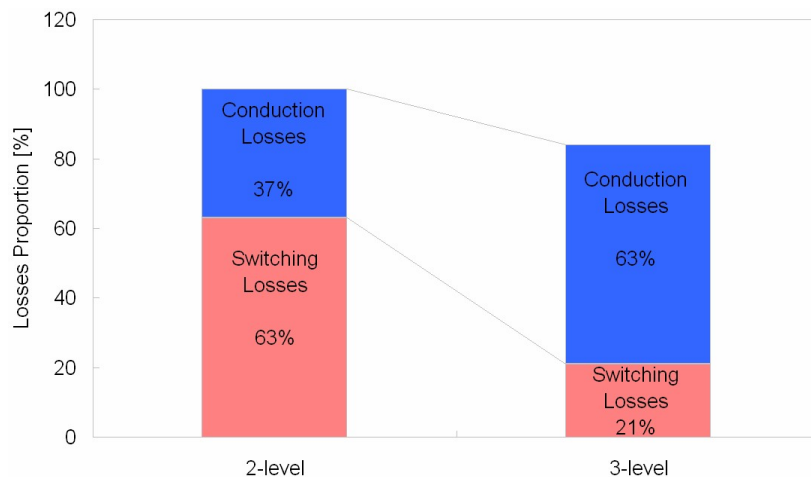

Power Module Optimization

In addition to the inherent benefits of the three-level topology, a tailored design of the power semiconductor modules provides further improvements in terms of component stress, noise and losses. Figure 11 shows an optimized IGBT power module for a medium capacity three-level uninterruptible power supply. This optimization provides higher efficiency, reliability and performance by means of selection of the IGBT chip technology as well as design of the integrated circuit.

FIGURE 11

A tailored power module for medium capacity three-level uninterruptible power supplies



An optimized power module contains advanced mature chip technology for high performance and reliability.

The IGBT chip inside this package features the latest significant advances in the power semiconductor industry and the proven, reliable record of an extremely mature technology. As a result, this combination offers great reduction of power losses, better thermal characteristics and higher reliability.

To further enhance the features of the chosen IGBT chip, internal circuit layout and component placement play a leading role in the power module design. This power module comprises an arm of a three-level converter as shown in the schematic of Figure 12. Its circuit integration design decreases parasitic inductances and reduces electromagnetic noise. Therefore power semiconductors inside this package experience lower stresses caused by switching surge voltage.

FIGURE 12
Schematic circuit of the
tailored power module
for medium capacity
three-level
uninterruptible power

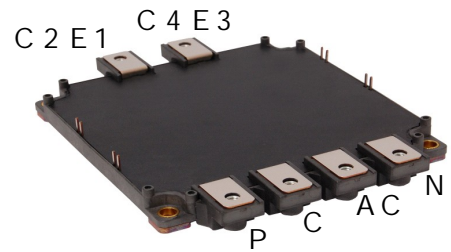
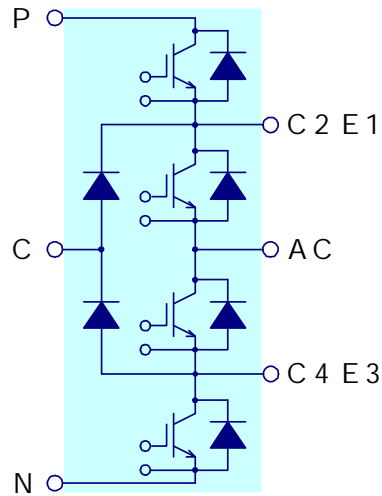

The final result is an exclusive IGBT power module for an innovative circuit concept. Its tailored design boosts the benefits of three-level power converters by

- n increasing efficiency by reduction of semiconductor power losses;
- n improving reliability through lower electrical and thermal stresses;
- n reducing electromagnetic noise due to its intelligent circuit design.

G9000 UPS Benefits

As the world's first three-level uninterruptible power supply, the G9000 UPS is the wise response from Toshiba to the growing demand for high reliability and efficient power solution for mission-critical applications. Its innovative three-level circuit concept and exclusive power module delivers superior performance and reliability, updates industrial electronics technology and reduces cost of ownership with its green-oriented features.

G9000 UPS includes advances in all the three levels in power electronics: circuits, components and systems.

The many benefits of the G9000 UPS include:

n **Industry-leading and up-to-date power electronics technology**

The G9000 UPS is the most advanced uninterruptible power supply. Advances comprise all the three levels in power electronics: circuits, components, and systems. The innovative three-level circuit concept is a milestone in the UPS industry, which has stagnated to the conventional two-level topology. The exclusive power module has become a key component to make the multilevel concept even more attractive. In terms of advances in systems, DSP⁴-based fully digital control ensures superior performance to meet modern industry demands and standards. In addition, The G9000 UPS introduces a cross current sensor less control for parallelism of multiple modules. This new technology eases the system expansion toward a redundant high-reliability configuration.

G9000 UPS features industry-leading double conversion efficiency (>96%).

n **Green-oriented design**

With an unmatched efficiency of 96.5% at full load, The G9000 UPS is the greenest double-conversion UPS on market while competitors barely reaches 95%. This high efficiency leads to significant energy savings as well as reduction of the carbon footprint. To illustrate the amount of energy savings, consider two 225-kVA systems running at 40% load. The impressive double conversion efficiency curve (Figure 13) of the G9000 UPS shows >96% efficiency even at this load percentage. In this case, an increase of 1% in efficiency represents

⁴ Digital signal processor

\$21,287 of savings for 15 years of operation⁵. Further savings can actually be achieved when considering cooling as well. Translating into emission of CO₂, the same increase of 1% in efficiency represents a reduction of 285,243 lbs of CO₂ in a 15-year period⁶. Besides the energy savings, another environment-friendly feature is the reduction of electromagnetic noise owing to the innovative three-level circuit concept and its exclusive power module. Since environmental regulations change from time to time, the G9000 UPS is the most suitable long-term power protection solution to stay ahead of the future.

FIGURE 13
Double conversion
efficiency curve of the
225 kVA G9000 UPS

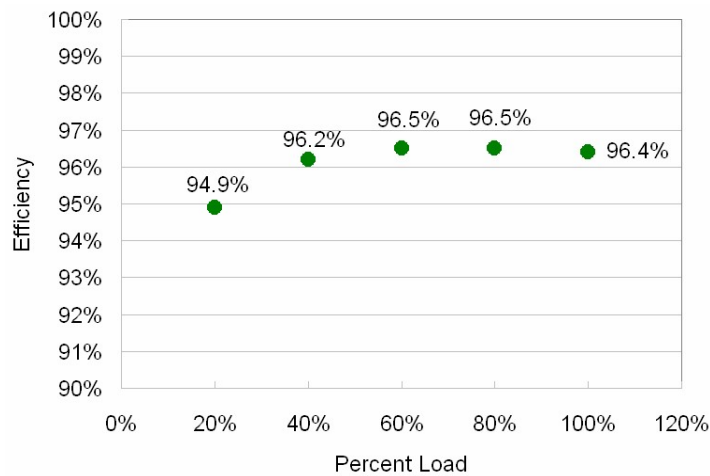

n **Better utilization of available space**

Its transformerless, all-transistorized, three-level circuit design results in a high power density UPS with small footprint and low weight. The 225kVA G9000 UPS occupies an area of 8.11 square feet (7,542 square centimeters) and weights only 1230 lbs (558 kg). These characteristics promote a considerable reduction of shipment costs when compared with conventional UPS with similar specification. Its small footprint facilitates reconfiguration if needed and helps to save space and infrastructure in expensive environmentally controlled facilities.

⁵ Cost of electricity at about \$0.10/kWh based on a rough estimative from: Energy Information Administration, "Average Retail Price of Electricity to Ultimate Customers by End-Use Sector" (2007)

⁶ US national average from: Energy Information Administration, "Updated state-level greenhouse gas emission coefficients for electricity generation 1998-2000" (2002).

Conclusions

The G9000 UPS is the advanced silicon rich uninterruptible power supply for a long-term value creation in critical-mission facilities. Its industry leading power electronics technology delivers unmatched double conversion efficiency and competitive size/weight reduction to meet current and future demands in terms of greenhouse emissions, redundancy, and layout reconfiguration. With a wide range of benefits, the G9000 UPS avoids technological obsolescence, reduces waste and enhances flexibility. The G9000 UPS is a 480V 60Hz UPS available in 80, 100, 160, and 225kVA capacities.

To find out more about the G9000 UPS, visit www.toshiba.com/ind.